



Hi3516D Professional HD IP Camera SoC

## **Brief Data Sheet**

<b>Issue</b>	<b>01</b>
<b>Date</b>	<b>2014-12-22</b>

**Copyright © HiSilicon Technologies Co., Ltd. 2014. All rights reserved.**

No part of this document may be reproduced or transmitted in any form or by any means without prior written consent of HiSilicon Technologies Co., Ltd.

### **Trademarks and Permissions**



**HISILICON**, and other HiSilicon icons are trademarks of HiSilicon Technologies Co., Ltd.

All other trademarks and trade names mentioned in this document are the property of their respective holders.

### **Notice**

The purchased products, services and features are stipulated by the contract made between HiSilicon and the customer. All or part of the products, services and features described in this document may not be within the purchase scope or the usage scope. Unless otherwise specified in the contract, all statements, information, and recommendations in this document are provided "AS IS" without warranties, guarantees or representations of any kind, either express or implied.

The information in this document is subject to change without notice. Every effort has been made in the preparation of this document to ensure accuracy of the contents, but all statements, information, and recommendations in this document do not constitute a warranty of any kind, express or implied.

## **HiSilicon Technologies Co., Ltd.**

Address: Huawei Industrial Base  
Bantian, Longgang  
Shenzhen 518129  
People's Republic of China

Website: <http://www.hisilicon.com>

Email: [support@hisilicon.com](mailto:support@hisilicon.com)



# Hi3516D Professional HD IP Camera SoC

## Key Specifications

### Processor Core

- A7@600 MHz, 32 KB I-cache, 32 KB D-cache/128 KB L2 cache
- Neon acceleration, integrated FPU

### Video Encoding

- H.264 BP/MP/HP
- H.265 main profile
- MJPEG/JPEG baseline encoding

### Video Encoding Performance

- A maximum of 5-megapixel resolution for H.264/H.265 encoding
- Real-time H.264/H.265 encoding of multiple streams:
  - 1080p@30 fps+720p@30 fps+VGA@30 fps
  - 3-megapixel@30 fps+VGA@30 fps
  - 5-megapixel@15 fps
- JPEG snapshot at 5-megapixel@8 fps
- Supporting the CBR/VBR bit rate control mode, ranging from 16 kbit/s to 40 Mbit/s
- Encoding frame rate ranging from 1/16 fps to 240 fps
- Encoding of eight ROIs

### Intelligent Video Analysis

- Integrated IVE, supporting various intelligent analysis applications such as motion detection, boundary security and video diagnosis

### Video and Graphics Processing

- 3D denoising, image enhancement, and dynamic contrast enhancement
- Anti-flicker for output videos and graphics
- 1/15.99x to 16x video scaling
- 1/2x to 2x graphics scaling
- OSD overlay pre-processing for eight regions
- Video graphics overlaying of two layers (video layer and graphics layer)

### ISP

- Adjustable 3A functions (AE, AWB, and AF)
- Noise reduction in FPN mode
- Highlight compensation, backlight compensation, gamma correction, and color enhancement
- Defect pixel correction, denoising, and digital image stabilizer
- Anti-fog
- Lens distortion correction
- Picture rotation by 90° or 270°
- Mirroring and flipping
- Digital WDR, frame base/line base WDR, and tone mapping

- ISP tuning tools for the PC

### Audio Encoding/Decoding

- Voice encoding/decoding in compliance with multiple protocols by using software
- G.711, ADPCM, and G.726 protocols
- AEC, ANR, and ALC

### Security Engine

- Various encryption and decryption algorithms using hardware, such as AES, DES, and 3DES
- Digital watermark

### Video Interfaces

- Input
  - 8-/10-/12-/14-bit RGB Bayer DC timing VI, a maximum of 150 MHz clock frequency
  - BT.601, BT.656 or BT.1120 VI interface
  - MIPI, LVDS/sub-LVDS, and HiSPI
  - Compatibility with mainstream HD CMOS sensors provided by Sony, Aptina, OmniVision, and Panasonic
  - Compatibility with the electrical specifications of parallel and differential interfaces of various sensors
  - Programmable sensor clock output
  - Maximum input resolution of 5 megapixels
- Output
  - One PAL/NTSC output for automatic load detection
  - One BT.1120/BT.656 VO interface for connecting to an external HDMI or SDI, up to 1080p@60 fps output

### Audio Interfaces

- Integrated audio CODEC, supporting 16-bit audio inputs and outputs
- I<sup>2</sup>S interface for connecting to an external audio CODEC

### Peripheral Interfaces

- POR
- One integrated high-precision RTC
- One dual-channel SAR ADC
- Four UART interfaces
- One IR interface, three I<sup>2</sup>C interfaces, four SPI master interfaces, 14 x 8 + 3 GPIO interfaces
- Eight PWM interfaces (four independent interfaces and four multiplexed with other pins)
- Two SDIO 3.0 interfaces, supporting SDXC
- One USB 2.0 host/device port
- RGMII/RMII/MII in 100/1000 Mbit/s full-duplex or half-duplex mode, PHY clock output, and TSO network acceleration

### External Memory Interfaces

- DDR3/3L SDRAM interface
  - One 16-bit DDR3/3L interface with the maximum frequency of 600 MHz (1.2 Gbit/s)
  - Maximum capacity of 4 Gbits for a 16-bit DDR



## Hi3516D Professional HD IP Camera SoC

- SPI NOR flash interface
  - 1-, 2-, or 4-wire mode
  - Maximum capacity of 32 MB
- SPI NAND flash interface
  - Maximum capacity of 4 Gbits
- NAND flash interface
  - 8-bit data width
  - SLC or MLC
  - 4-, 8-, or 24-bit ECC
  - Components with 8 GB capacity or larger
- Booting from the SPI NOR flash, SPI Nand Flash or NAND flash

### SDK

- Linux-3.4-based SDK
- High-performance H.264/H.265 PC decoding library

### Physical Specifications

- Power consumption
  - 900 mW typical power consumption
  - Multi-level power-saving mode
- Operating voltages
  - 1.1 V core voltage
  - 3.3 V I/O voltage and 3.8 V margin voltage
  - 1.35 V or 1.5 V DDR3/3L SDRAM interface voltage
- Package
  - Body size of 15 mm x 15 mm (0.59 in. x 0.59 in.), 0.65 mm (0.03 in.) ball pitch, TFBGA RoHS

# Hi3516D Professional HD IP Camera SoC

## Functional Block Diagram

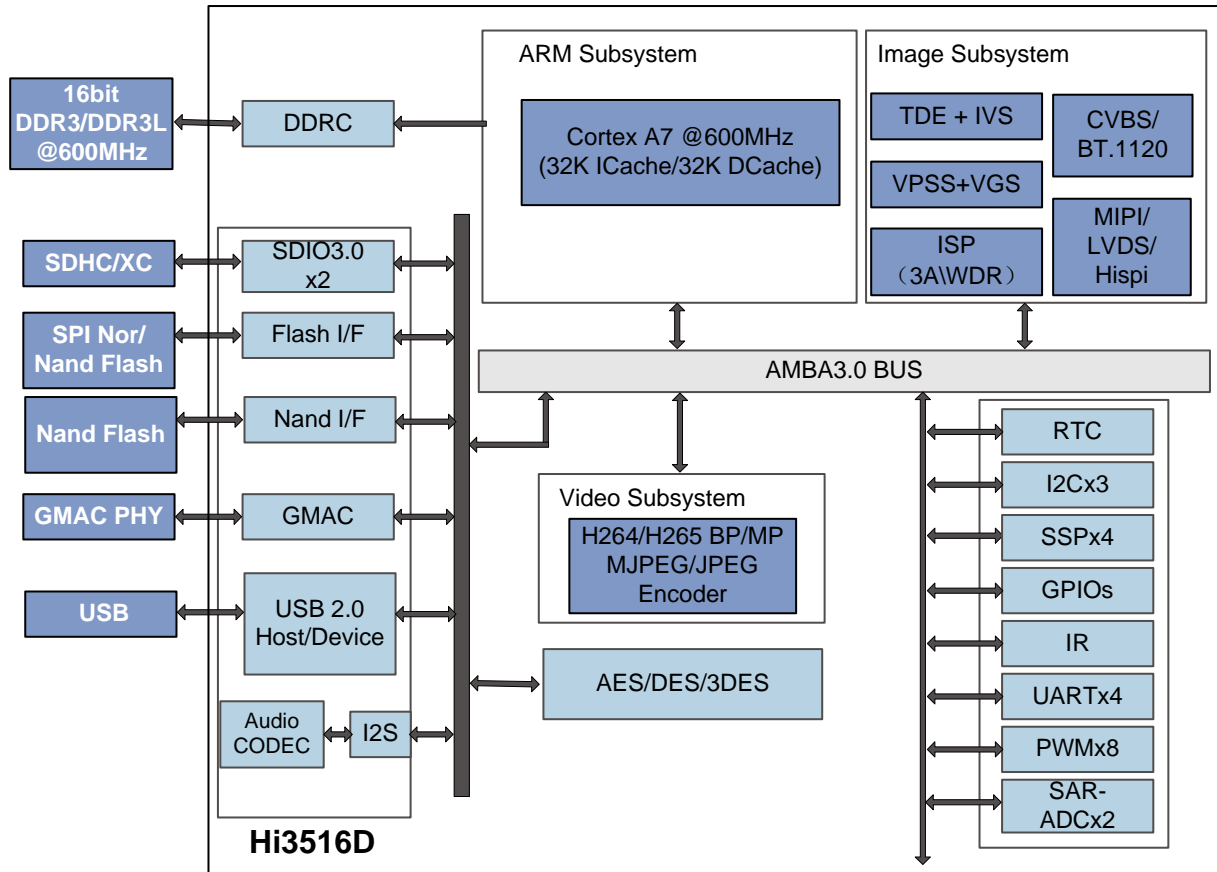

As a new-generation SoC designed for the HD IP camera, the Hi3516D integrates a new-generation ISP and adopts the latest H.265 compressed video encoder, advanced low-power technology, and low-power architecture design. These features help the Hi3516D keep the leading position in the aspects of low bit rate, high picture quality, and low power consumption. The Hi3516D supports 90° or 270° rotation and lens distortion correction, which meets requirements in various surveillance applications. It also fully supports 3A algorithms, which allow customers to design different types of IP cameras including the IP AF zoom module. The Hi3516D integrates the POR, RTC, and audio CODEC and supports various sensor levels and clock outputs, which significantly reduces the EBOM costs for the Hi3516D HD IP camera. Similar to other HiSilicon DVR and NVR SDKs, the Hi3516D SDK features high stability and ease of use, which allows rapid mass production and facilitates system layout of IP cameras, DVRs, and NVRs.

# Hi3516D Professional HD IP Camera SoC

## Hi3516D HD IP Camera Solution

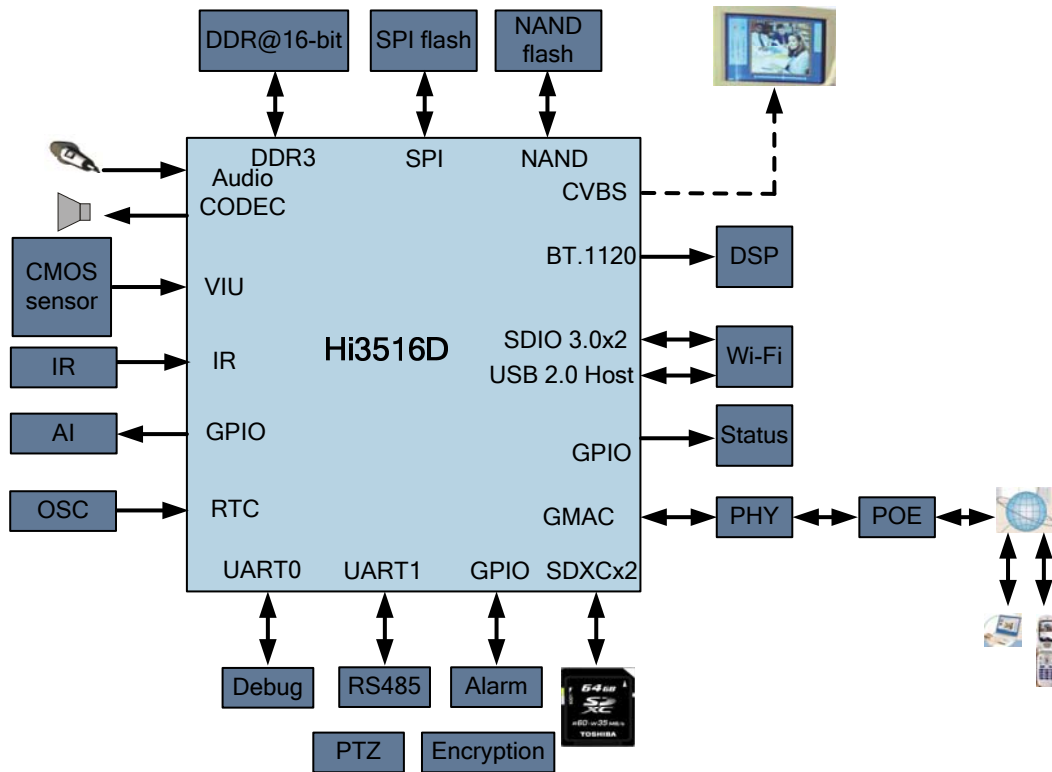

## Acronyms and Abbreviations

3DES	triple data encryption standard
ABR	average bit rate
ADC	analog-to-digital converter
AE	automatic exposure
AEC	acoustic echo cancellation
AES	advanced encryption standard
AF	automatic focus
ALC	auto level control
ANR	audio noise reduction
AWB	automatic white balance
CBR	constant bit rate
CMOS	complementary metal-oxide semiconductor
CODEC	coder/decoder
DES	data encryption standard
DVR	digital video recorder
ECC	error correcting code
FPN	fixed pattern noise
FPU	floating point unit
GPIO	general-purpose input/output
HD	high definition
HDMI	high-definition multimedia interface
I <sup>2</sup> C	inter-integrated circuit



## Hi3516D Professional HD IP Camera SoC

I <sup>2</sup> S	inter-IC sound
IR	infrared
ISP	image signal processor
LVDS	low-voltage differential signaling
IVE	intelligent video engine
MIPI	mobile industry processor interface
MLC	multi-level cell
NTSC	National Television Systems Committee
NVR	network video recorder
OSD	on-screen display
PAL	phase alternating line
PHY	physical
POR	power-on-reset
PWM	pulse width modulation
RGMI	reduced gigabit media independent interface
RMII	reduced media independent interface
RoHS	Restrictions on the Use of Certain Hazardous Substances
ROI	region of interest
RTC	real-time clock
SAR	successive approximation
SDI	serial digital interface
SDIO	secure digital input/output
SDK	software development kit
SDRAM	synchronous dynamic random access memory
SDXC	secure digital extended capacity
SLC	single-level cell
SoC	system-on-chip
SPI	serial peripheral interface
TFBGA	thin & fine-pitch ball grid array
TSO	TCP segmentation offload
UART	universal asynchronous receiver transmitter
VBR	variable bit rate
VI	video input
VO	video output
WDR	wide dynamic range